

REV.	ECN NO.	NAME	DATA
A0	NEW	MIN-D	2020-06-22

SPECIFICATION NOTES:

ELECTRICAL:

- VOLTAGE RATING: 125 VAC RMS
- CURRENT RATING: 15 AMP
- CONTACT RESISTANCE: 30mΩ MAX.
- INSULATION RESISTANCE: 500MΩMIN. AT 500V DC.
- DIELECTRIC STRENGTH: 1000 VAC 50Hz 1MINUTE

MECHANICAL:

- 1.HOUSING MATERIAL:**
SEE PART NUMBER.
- CONTACTS:Ø0.46mm PHOSPHOR BRONZE,GOLD PLATING OVER NICKEL
 - SHIELD:0.20mm THICKNESS COPPER ALLOY WITH NICKEL PLATED.
 - OPERATING LIFE:750 CYCLES MIN.
 - MATING FORCE: 22N MAX.
 - UNMATING FORCE: 22N MAX.
 - Wave soldering Temp: 235*+/-5*

ENVIRONMENTAL:

- STORAGE:-40°C TD +85°C
- OPERATION:-40°C TD +85°C

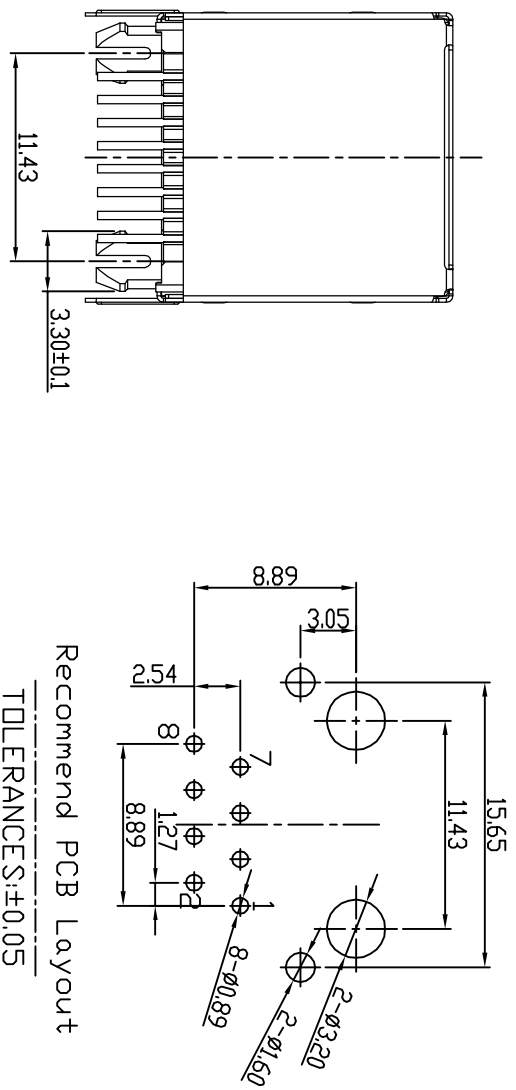
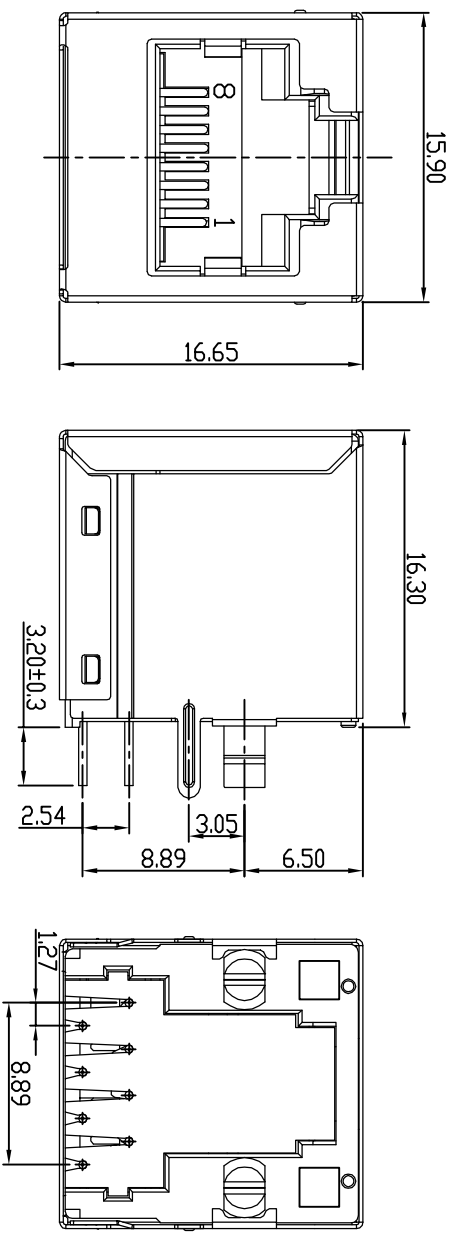

Recommend PCB Layout
TOLERANCES:±0.05

52-XX 88 X X X 1 -A

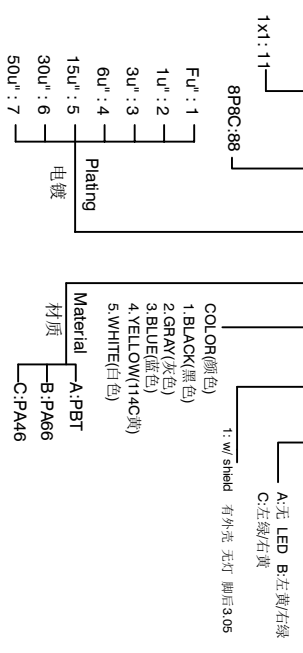

DETACHED LISTS		公差 TOLERANCES		审核 (Checked)		材料 (Material)		图号 (DWG NO.):		名称 (NAME)	
MM	MM	0.0 ± 0.20	0 ± 0.38	批准 (Approved)	材料 (Material)	图号 (DWG NO.):	名称 (NAME)	料号 (PART NO.):	版本 (REV)	图号 (DWG NO.):	名称 (NAME)
0.00 ± 0.15	0.00 ± 0.15	角度 (ANGLES) ± 1.5°	0.00 ± 0.15	比例 (SCALE)	SEE NOTES	料号 (PART NO.):	XWJ-52224 8P8C 全包 无灯 脚后3.05	52-XX88XXX1-A	A0	52-XX88XXX1-A	XIN WANG JIU Electronics Co.,Ltd
第三角视图				1:1		单位 (UNIT):	MM	共 (SHEET)	1	页 (OF)	1

1
2
3
4
5
6
7
8

A B C D E F G H

XWJ 东莞市欣旺久电子有限公司
XIN WANG JIU Electronics Co.,Ltd